

# Vigilohm IM10-H, IM15H, and IM20-H

## Insulation monitoring device for medical premises

### User manual

VIGED310023EN-04  
12/2018



# Legal Information

The Schneider Electric brand and any registered trademarks of Schneider Electric Industries SAS referred to in this guide are the sole property of Schneider Electric SA and its subsidiaries. They may not be used for any purpose without the owner's permission, given in writing. This guide and its content are protected, within the meaning of the French intellectual property code (Code de la propriété intellectuelle français, referred to hereafter as "the Code"), under the laws of copyright covering texts, drawings and models, as well as by trademark law. You agree not to reproduce, other than for your own personal, noncommercial use as defined in the Code, all or part of this guide on any medium whatsoever without Schneider Electric's permission, given in writing. You also agree not to establish any hypertext links to this guide or its content. Schneider Electric does not grant any right or license for the personal and noncommercial use of the guide or its content, except for a non-exclusive license to consult it on an "as is" basis, at your own risk. All other rights are reserved.

Electrical equipment should be installed, operated, serviced, and maintained only by qualified personnel. No responsibility is assumed by Schneider Electric for any consequences arising out of the use of this material.

As standards, specifications, and designs change from time to time, please ask for confirmation of the information given in this publication.

# Safety information

## Important information

Read these instructions carefully and look at the equipment to become familiar with the device before trying to install, operate, service, or maintain it. The following special messages may appear throughout this manual or on the equipment to warn of potential hazards or to call attention to information that clarifies or simplifies a procedure.



The addition of either symbol to a “Danger” or “Warning” safety label indicates that an electrical hazard exists which will result in personal injury if the instructions are not followed.



This is the safety alert symbol. It is used to alert you to potential personal injury hazards. Obey all safety messages that accompany this symbol to avoid possible injury or death.

### ⚠ DANGER

**DANGER** indicates a hazardous situation which, if not avoided, **will result in death or serious injury**.

**Failure to follow these instructions will result in death or serious injury.**

### ⚠ WARNING

**WARNING** indicates a hazardous situation which, if not avoided, **could result in death or serious injury**.

### ⚠ CAUTION

**CAUTION** indicates a hazardous situation which, if not avoided, **could result in minor or moderate injury**.

### NOTICE

NOTICE is used to address practices not related to physical injury.

## Please note

Electrical equipment should be installed, operated, serviced and maintained only by qualified personnel. No responsibility is assumed by Schneider Electric for any consequences arising out of the use of this material. A qualified person is one who has skills and knowledge related to the construction, installation, and operation of electrical equipment and has received safety training to recognize and avoid the hazards involved.

## Notices

### FCC

This equipment has been tested and found to comply with the limits for a Class B digital device, pursuant to part 15 of the FCC rules. These limits are designed to provide reasonable protection against harmful interference in a residential installation. This equipment generates, uses, and can radiate radio frequency energy and, if not installed and used in accordance with the instructions, may cause harmful interference to radio communications. However, there is no guarantee that the interference will not occur in a particular installation. If this equipment does cause harmful interference to radio or television reception, which can be determined by turning the equipment off and on, the user is encouraged to try to correct the interference by one or more of the following measures:

- Reorient or relocate the receiving antenna.
- Increase the separation between the equipment and receiver.
- Connect the equipment to an outlet on a circuit different from that to which the receiver is connected.
- Consult the dealer or an experienced radio/TV technician for help.

The user is cautioned that any changes or modifications not expressly approved by Schneider Electric could void the user's authority to operate the equipment.

This digital apparatus complies with CAN ICES-3 (B) /NMB-3(B).

## About this manual

This manual discusses features of the Vigilohm IM10-H, IM15H, and IM20-H insulation monitoring devices (IMDs) and provides installation, commissioning, and configuration instructions.

This manual is intended for use by designers, panel builders, installers, system integrators, and maintenance technicians who are related with ungrounded electrical distribution systems featuring insulation monitoring devices (IMDs) for medical applications.

Throughout the manual, the term “device” refers to Vigilohm IM10-H, IM15H, and IM20-H. All differences between the models, such as a feature specific to one model, are indicated with the appropriate model number or description.

This manual assumes you have an understanding of insulation monitoring and are familiar with the equipment and power system in which your device is installed.

Please contact your local Schneider Electric representative to learn what additional training opportunities are available for your devices.

Make sure you are using the most up-to-date version of your device’s firmware in order to access the latest features.

The most up-to-date documentation for your device is available for download from [www.schneider-electric.com](http://www.schneider-electric.com).

### Related documents

Document	Number
Instruction Sheet: Vigilohm IM10-H Insulation Monitoring Device	S1A40440
Instruction Sheet: Vigilohm IM15H and IM20-H Insulation Monitoring Device	S1A40442
Vigilohm Catalog	PLSED310020EN, PLSED310020FR
Secure power distribution and monitoring solution for operating theatres - Solution guide	DESWED109024EN
Solution de distribution électrique sécurisée et de surveillance pour blocs opératoires - Guide de la solution	DESWED109024FR



# Table of Contents

Safety precautions .....	9
Introduction .....	11
Ungrounded power system overview .....	11
Insulation resistance (R) monitoring .....	11
Device Overview .....	11
Device features .....	12
Hardware overview .....	12
Supplemental information.....	13
Hospital Remote Panel (HRP) .....	13
Local Remote Display (LRDH) .....	16
Description .....	18
Dimensions .....	18
Flush-mounting and dismounting .....	18
Mounting .....	18
Dismounting .....	19
DIN rail mounting and dismounting.....	20
Mounting .....	20
Dismounting .....	20
Wiring diagram of IM10-H and IM15H / IM20-H .....	21
Example application: IM10-H and HRP .....	22
Example application: IM15H / IM20-H, HRP, and supervisor.....	23
Functions.....	25
Monitoring power system insulation.....	25
Insulation Alarm Relay Acknowledgement .....	27
Transformer Monitoring .....	29
Self-test .....	30
Human Machine Interface .....	32
Vigilohm IM10-H menu.....	32
Vigilohm IM15H / IM20-H menu .....	32
Display interface .....	33
Navigation buttons and icons.....	34
Information icons .....	34
Status screens .....	35
Parameter modification using the display.....	36
Clock .....	37
Insulation fault log.....	37
Communication .....	39
Communication Parameters .....	39
Modbus functions .....	39
Modbus registers table .....	40
Maintenance .....	48
Troubleshooting.....	49
Specifications .....	50





# Safety precautions

Installation, wiring, testing and service must be performed in accordance with all local and national electrical codes.

## Specific hazard associated with Insulation Monitoring Devices (IMDs)

Insulation monitoring devices are connected to the system via an injection wire, which must be disconnected before carrying out any kind of work on the product.

<b>⚠ DANGER</b>
<p><b>HAZARD OF ELECTRIC SHOCK, EXPLOSION, OR ARC FLASH</b></p> <p>Disconnect the injection wire from the device to the monitored system before working on the device or equipment.</p> <p><b>Failure to follow these instructions will result in death or serious injury.</b></p>

## Other safety measures

<b>⚠ DANGER</b>
<p><b>HAZARD OF ELECTRIC SHOCK, EXPLOSION, OR ARC FLASH</b></p> <ul style="list-style-type: none"> <li>• Apply appropriate personal protective equipment (PPE) and follow safe electrical work practices. See NFPA 70E in the USA, CSA Z462 or applicable local standards.</li> <li>• Turn off all power supplying this device and the equipment in which it is installed before working on the device or equipment.</li> <li>• Always use a properly rated voltage sensing device to confirm that all power is off.</li> <li>• Treat communications and I/O wiring connected to multiple devices as hazardous live until determined otherwise.</li> <li>• Do not exceed the device's ratings for maximum limits.</li> <li>• Disconnect all the device's input and output wires before performing dielectric (hi-pot) or Megger testing.</li> <li>• Never shunt an external fuse or circuit breaker.</li> </ul> <p><b>Failure to follow these instructions will result in death or serious injury.</b></p>

**NOTE:** See IEC 60950-1:2005, Annex W for more information on communications and I/O wiring connected to multiple devices.

<b>⚠ WARNING</b>
<p><b>UNINTENDED OPERATION</b></p> <p>Do not use this device for critical control or protection applications where human or equipment safety relies on the operation of the control circuit.</p> <p><b>Failure to follow these instructions can result in death, serious injury, or equipment damage.</b></p>

***NOTICE*****EQUIPMENT DAMAGE**

- Do not open the device case.
- Do not attempt to repair any components of the device.

**Failure to follow these instructions can result in equipment damage.**

# Introduction

## Ungrounded power system overview

Ungrounded power system is an earthing system, which increases continuity of service of power systems and protection of people and property.

This system varies from country to country, including some applications where this system is mandated, such as hospital and the naval applications. This system is typically used in instances where the unavailability of power could result in lost production or incur significant downtime costs. Other potential applications are when there is a need to minimize the risk of fire and explosion. Lastly, this system is chosen in certain cases because it can facilitate preventive and corrective maintenance operations.

The system transformer's neutral is isolated from earth, or there is a high impedance between the neutral and earth, while the electrical load frames are earthed. This isolates the transformer and the load such that if the first fault occurs there is no loop for shorting current to flow, allowing the system to continue to operate normally without hazard to people and equipment. This system must have very low network capacitance to ensure that the first fault current cannot generate significant voltage. However, the faulty circuit must be detected and repaired before a second fault occurs. Because this system can tolerate an initial fault, maintenance operations can be improved and carried out in a safe and convenient manner.

## Insulation resistance (R) monitoring

Ungrounded power system require insulation monitoring to identify when the first insulation fault has occurred.

In ungrounded power system, the installation must either be ungrounded or must be grounded using a sufficiently high level of impedance.

In the event of only one ground or earth fault, the fault current is very low and interruption is unnecessary. However, given that a second fault could potentially cause the circuit breaker to trip, an insulation monitoring device has to be installed to indicate an initial fault. This device must trigger an audible and/or a visual signal.

By constantly monitoring the insulation resistance, you can keep track of the system quality, which is a form of preventive maintenance.

## Device Overview

The device is a digital insulation monitoring device (IMD) for low-voltage ungrounded power systems. They monitor the insulation of a power system and notify any insulation faults as soon as they occur.

IMD monitors the insulation resistance of the system by injecting a signal. This technique is used for all power system types - AC, DC, combined, rectified, with a variable speed drive, etc.

IM10-H, IM15H, and IM20-H devices offer the following features:

- Insulation resistance display (R)
- Detection of insulation faults in accordance with a configurable threshold
- Detection of a lost connection (ground or injection)

IM15H and IM20-H offers these additional features:

- Insulation fault log
- Transformer monitoring:

- Display of load current for secondary (as a percentage)
- Threshold-based triggering of an alarm (as a percentage of nominal current)
- Temperature alarm (bimetal contact)

IM20-H offers communication via the ModbusRS-485 protocol feature.

## Device features

The features supported depend on the device model.

Function	IM10-H	IM20-H	IM15H
Measurement and display of ungrounded system insulation resistance	√	√	√
Threshold-based triggering of alarm	√	√	√
Transformer overload alarm	–	√	√
Transformer high temperature alarm	–	√	√
Time-tagged log (insulation faults, overloads, and transformer overheating events)	–	√	√
Communication via Modbus RS-485	–	√	–
Remote compatibility in operating room (Vigilohm HRP)	√	√	√
Remote compatibility in operating room (Vigilohm Local Remote Display)	–	√	–

## Hardware overview

Vigilohm IM10-H ,IM20-H, and IM15H feature 3, 6, and 5 terminal blocks respectively (identifiers A to F).

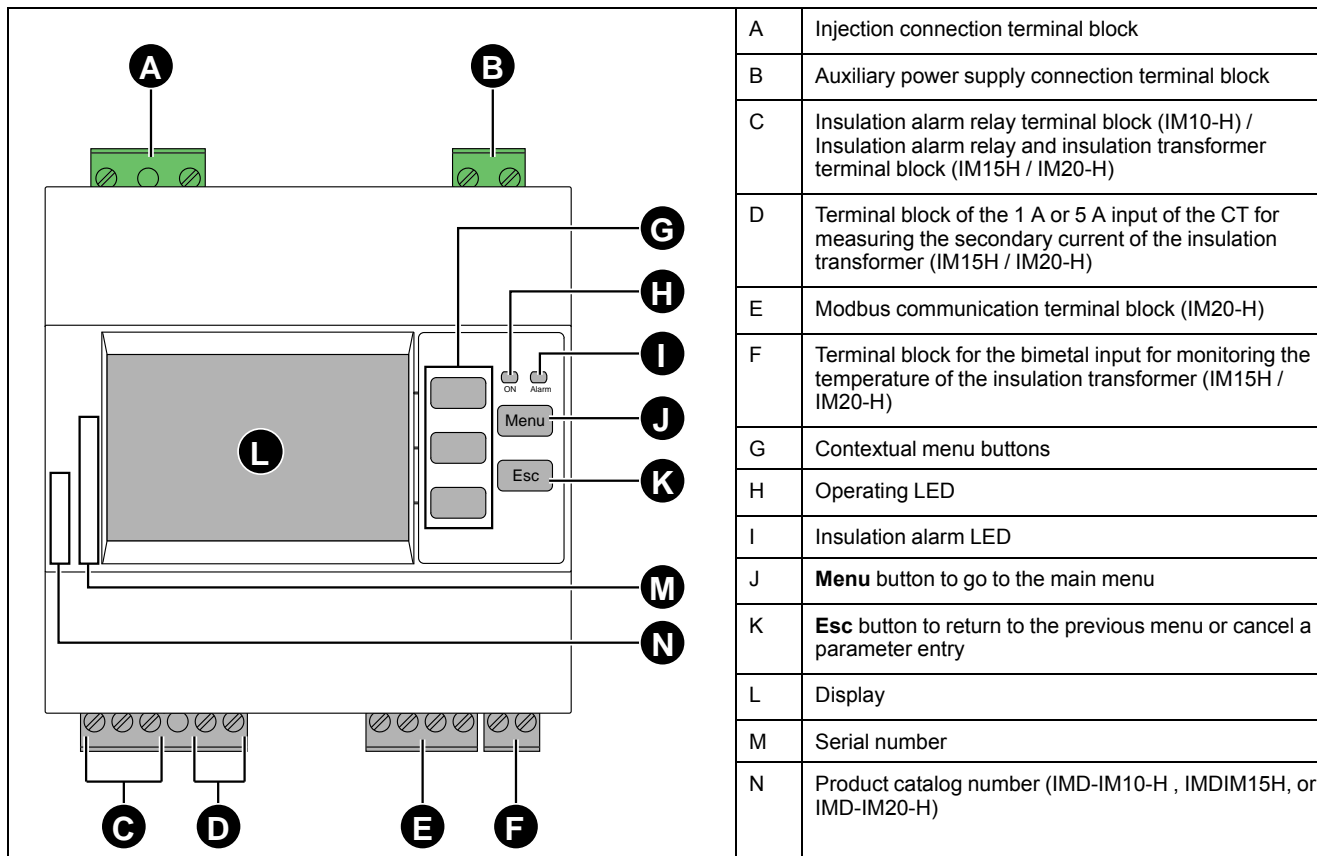

## Supplemental information

This document is intended to be used in conjunction with the installation sheet that ships in the box with your device and accessories.

See your device's installation sheet for information related to installation.

See your product's catalog pages at [www.schneider-electric.com](http://www.schneider-electric.com) for information about your device, its options and accessories.

You can download updated documentation from [www.schneider-electric.com](http://www.schneider-electric.com) or contact your local Schneider Electric representative for the latest information about your product.

## Hospital Remote Panel (HRP)

The HRP (Commercial reference: 50168) is an accessory for operating rooms and serves as a user interface for the systems used to monitor electrical installations in hospitals.

The HRP installed in the operating theater enables the hospital staff to understand whether the installation is operating or whether there is a fault as per the following cases:

- Insulation fault affecting the electrical equipment of the operating theater
- Electrical fault following tripping of a protective circuit breaker or overloading of a current transformer

**NOTE:** When the HRP is connected to the system, the measured insulation resistance does not exceed 2 MΩ.

The physical description of the HRP is illustrated in the following figure:

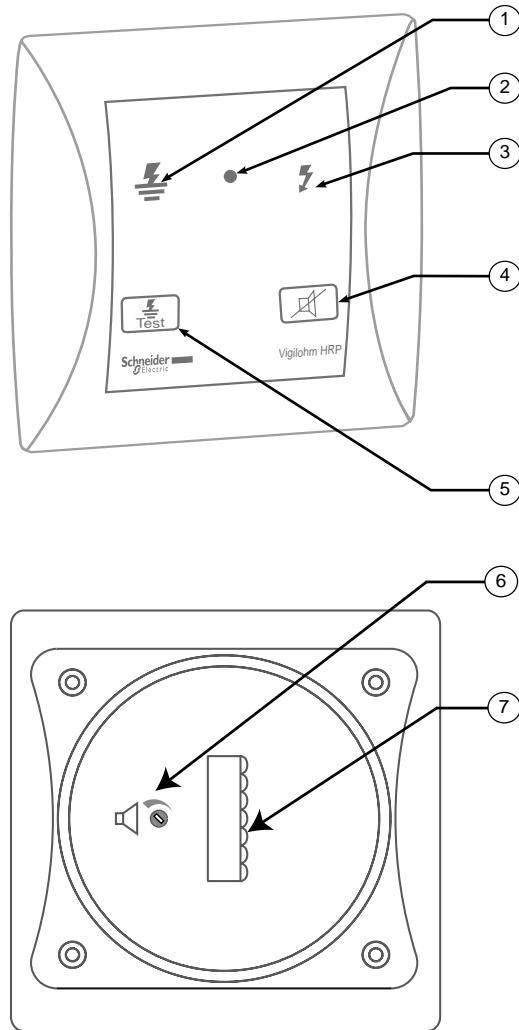

Number	Description
1	Yellow LED: Visual indication of an insulation fault
2	Green LED: Visual indication that the installation is operating
3	Red LED: Visual indication of an electrical fault (overload, overheating of the transformer, or tripping of a circuit breaker on fault)
4	Mute button
5	Push-button for testing the insulation monitoring system (daily test in accordance with standard IEC 60364-7-710)
6	Volume controller to adjust the alarm volume (Alarm volume is factory preset at 80 db. Use the volume controller to increase or decrease the volume)..
7	Connector

The HRP is flush-mounted on a partition. See the following figure for mounting information:

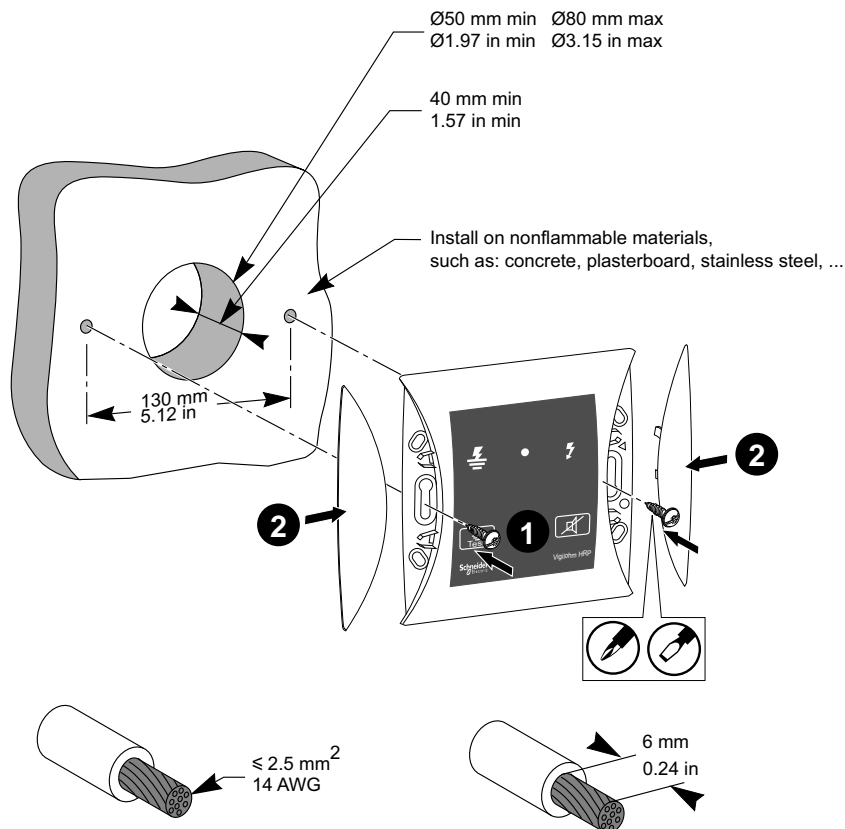

The HRP is connected to the insulation alarm relay terminal block. See wiring diagram from the device to the HRP ( *Wiring diagram of IM10-H and IM15H / IM20-H, page 21* ). The connector details of HRP is illustrated in the following figure:

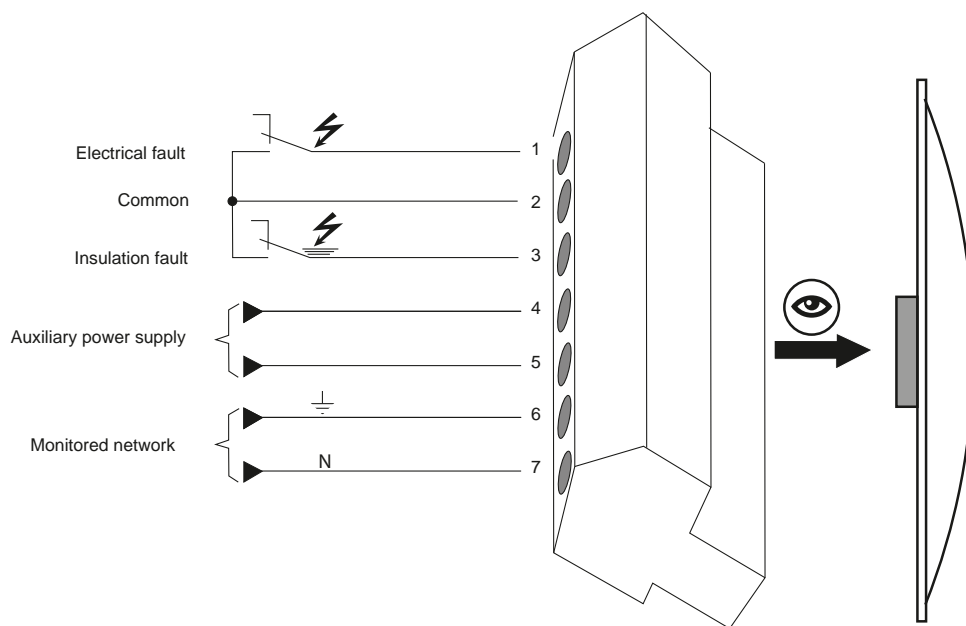

The characteristics of the HRP is as follows:

Characteristics		Value
<b>Mechanical Characteristics</b>		
Weight		0.5 kg (1.1 lbs)
Case	Plastic	Vertical mounting
Degree of protection		IP54
		IK08
Dimensions	Height	170 mm (6.69 in)

Characteristics		Value
	Width	170 mm (6.69 in)
	Depth	20 mm (0.79 in)
Audible alarm	Factory setting	80 db (adjustable)
Durable markings	Tested with 99% Isopropyl Alcohol	
<b>Electrical Characteristics</b>		
Auxiliary supply voltage	24 V DC	65 mA
<b>Environment</b>		
Operating temperature		0...40 °C
Storage temperature		-25...+70 °C
Maximum relative humidity		90%
Altitude		3000 m (9842 ft)
<b>Standards</b>		
Compliant with	IEC 60364-7-710	Medical facilities
	IEC 61557-8	Electrical safety
	IEC 60601-1	Electrical medical equipment
	IEC 61010-1	Electrical equipment safety

## Local Remote Display (LRDH)

Local Remote Display (LRDH) (Commercial Reference: IMDLRDH, Version: 1.0.0) is a digital, touch enabled and HMI equipped accessory for operating rooms in hospitals. This serves as a common user interface for the devices, which monitors electrical installation in hospitals. Local Remote Display is compatible with IM20-H.



Refer Local Remote Display *Installation Sheet (MFR40472)* for information on product contents, installation, configuration, setup, and specification.



Using Local Remote Display, the hospital staff can understand whether the electrical installation is operating normal or on fault. The fault is displayed as a message on the device along with the instructions to follow when fault occurs.

The following messages are displayed on the device and its description:

**NOTE:**

- Follow the instructions displayed whenever you see these message screens except **Installation Ready**.



- On any message except **Installation Ready**, the buzzer turns ON. Touch the  icon to turn OFF the buzzer.
- If multiple messages are displayed, touch and hold the  and  icons to navigate and view all the displayed messages.
- **Installation Ready**

This message displays when there is no fault in the system.
- **Insulation Fault**

This message displays when the system insulation is less than the set threshold.

You cannot acknowledge this message. This message continues to display until the system insulation is greater than the set threshold.
- **Transformer Overload**

This message displays when the system load current is greater than the set threshold.

You cannot acknowledge this message. This message continues to display until the system load current is less than the set threshold.
- **Transformer Overheat**

This message displays when the temperature sensor of the system transformer trips due to overheating.

You cannot acknowledge this message. This message continues to display until the system transformer temperature is less than the sensor threshold.
- **Product Error**

This message displays when the connected devices encounter an unknown error.

You cannot acknowledge this message. Contact Schneider Electric customer care representative for support.
- **System Error**

This message displays when there is an issue in the system.

You cannot acknowledge this message. This message continues to display until the system recovers from the issue.
- **Communication Error**

This message displays when the connected devices encounter communication issues.

To acknowledge this message, touch and hold the  icon for 2 seconds and release it. Check the communication settings of the highlighted devices.

**NOTE:** If the existing communication error is not fixed in 1 minute, this message displays again.

## Description

## Dimensions

Device dimensions and cut-out for flush mount is illustrated in the following figure:

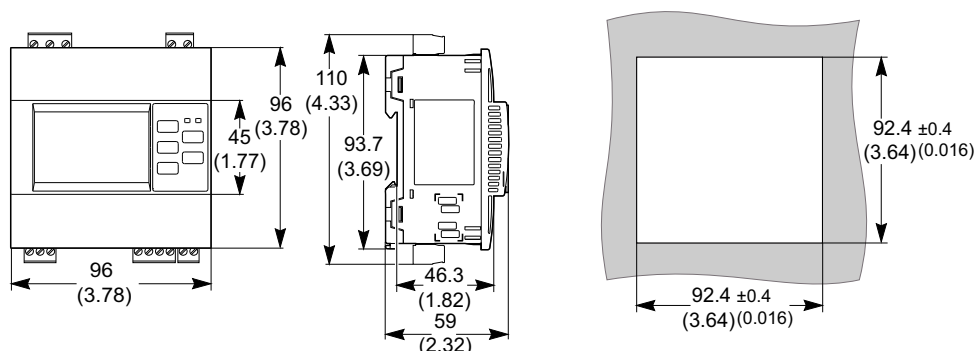

**NOTE:** All dimensions are measured in mm (in).

Observe the correct distances between devices for flush-mounting as per the following figure:

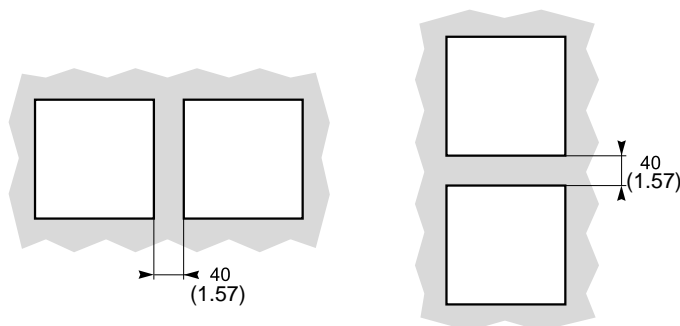

**NOTE:** All dimensions are measured in mm (in).

## Flush-mounting and dismounting

You can attach the device to any flat, rigid vertical support using the 3 spring clips supplied. You must not tilt the device after installation. To free up space for control gear, you can attach the device to the front panel of the floor-standing or wall-mounted enclosure.

## Mounting

Before installing the device, check the following:

- The mounting plate must have a thickness of between 0.8 (0.03) and 3.2 (0.13) mm (in).
- A square measuring 92 (3.62) x 92 (3.62) mm (in) must be cut out from the plate so the device can be installed.
- No terminal blocks may be connected to the unit.

1. Insert the device in the cut-out in the mounting plate by tilting the device forward slightly.

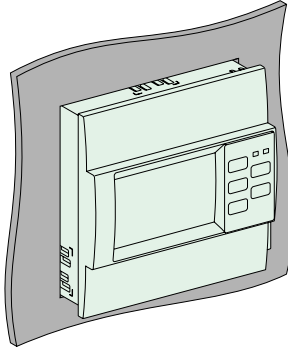

2. Depending on the thickness of the mounting plate, clip the 3 spring clips into the fixing slots on the device as follows:

Mounting plate thickness	Fixing slots to be used
$0.8 \text{ mm} \leq X \leq 2 \text{ mm}$ (0.031 in $\leq X \leq$ 0.079 in)	
$2 \text{ mm} < X \leq 3.2 \text{ mm}$ (0.079 in $< X \leq$ 0.126 in)	

3. Do the wiring and insert the terminal blocks as shown in the relevant wiring diagram (See *Wiring diagram of IM10-H and IM15H / IM20-H*, page 21) and as appropriate for the type of device concerned (See *Hardware overview*, page 12).

## Dismounting

1. Disconnect the terminal blocks from the device.

2. Insert the blade of a screwdriver between the spring clip and the device and use the screwdriver as a lever to release the spring clip.

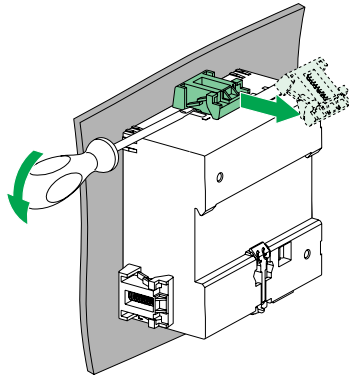

**NOTE:** Perform step 2 and 3 for the remaining 2 spring clips.

3. Reinsert the terminal blocks and make sure that the correct positions on the device are observed (See *Hardware overview*, page 12).

## DIN rail mounting and dismounting

You can install the device on a DIN rail. The device must not be tilted after installation.

### Mounting

1. Position the upper slots on the rear of the device on the DIN rail.
2. Press the device against the DIN rail until the locking mechanism engages.

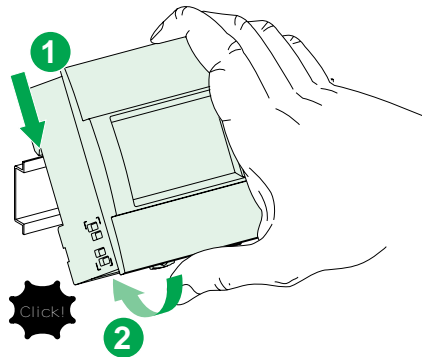

The device is fixed to the rail.

3. Do the wiring and insert the terminal blocks as shown in the relevant wiring diagram (See *Wiring diagram of IM10-H and IM15H / IM20-H*, page 21) and as appropriate for the type of device concerned (See *Hardware overview*, page 12).

### Dismounting

1. Disconnect the terminal blocks from the device.

- Use a flat screwdriver ( $\leq 6.5$  mm (0.26 in)) and push down the locking mechanism to release the device.

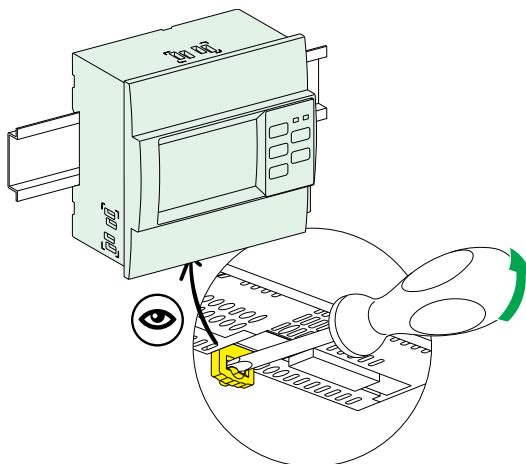

- Lift the device up to free it from the DIN rail.

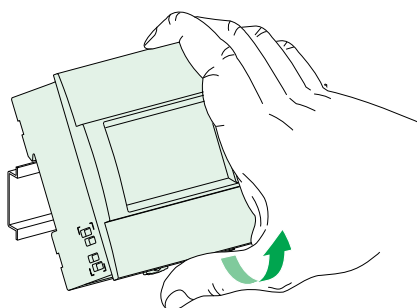

- Reinsert the terminal blocks and make sure that the correct positions on the device are observed (See *Hardware overview*, page 12).

## Wiring diagram of IM10-H and IM15H / IM20-H

All the device wiring terminals have identical wiring capabilities. The following are the list of characteristics of the cables that can be used to connect the terminals:

- Stripped length: 7 mm (0.28 in)
- Cable cross sectional area: 0.2 to 2.5 mm<sup>2</sup> (24 to 14 AWG)
- Tightening torque: 0.8 N m (7.1 lb in)
- Type of screwdriver: Flat, 3 mm (0.12 in)

Wiring diagram of IM10-H:

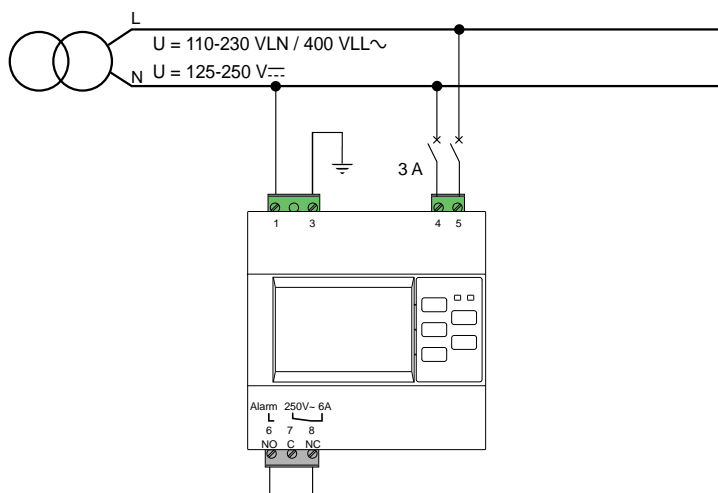

Wiring diagram of IM15H / IM20-H:

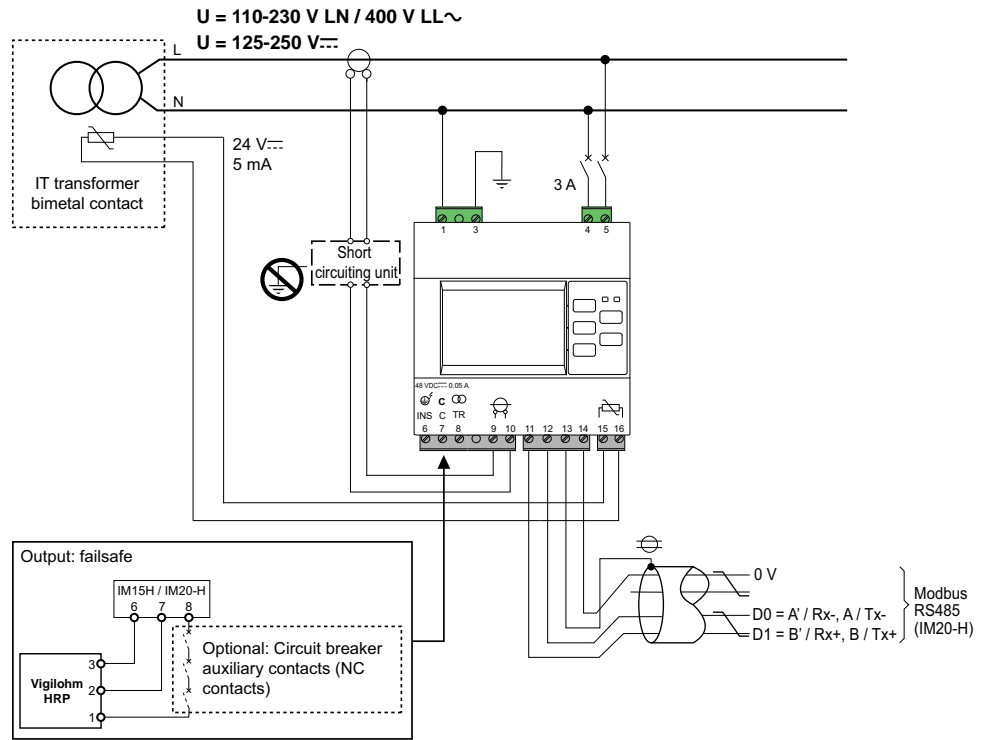

Wiring diagram from IM10-H to HRP:

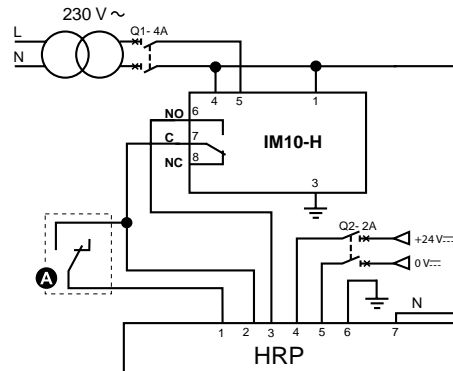

Wiring diagram from IM15H / IM20-H to HRP:

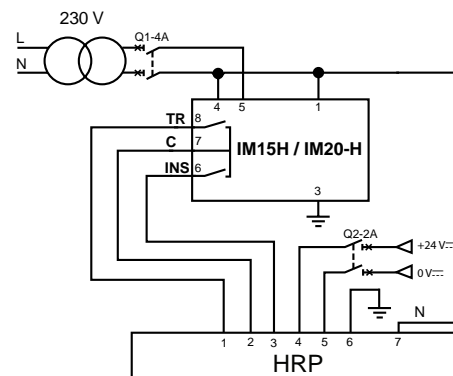

## Example application: IM10-H and HRP

An example of IM10-H and HRP installed in the medical premises.

Because, HRP is installed in the operating room the monitoring system can collate and display all the information relating to the insulation alarms generated by the electrical installation.

The HRP connection with operation theater cabinet is illustrated in the following figure:

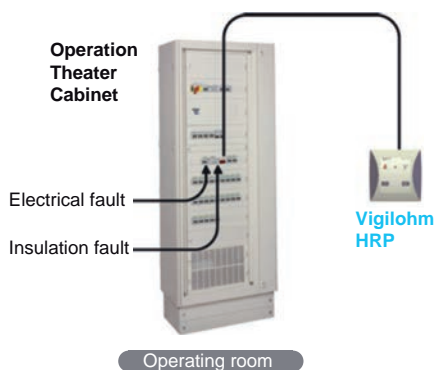

The HRP connection principle is illustrated in the following figure:

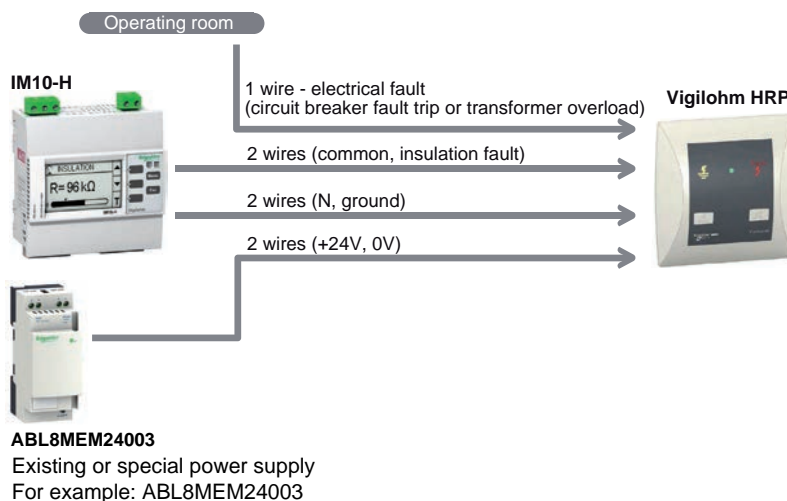

## Example application: IM15H / IM20-H, HRP, and supervisor

An example of IM15H / IM20-H and HRP installed in the medical premises along with supervisor connected via Modbus communication.

In addition to the features of IM10-H, the IM15H / IM20-H is used to transfer the transformer faults to the HRP. By using Modbus communication (IM20-H), the operating room staff or maintenance staff is provided with:

- Insulation value
- Load level of the transformer
- Insulation and transformer alarms
- Timestamped events

The HRP, operation theater cabinet, and supervisor connection is illustrated in the following figure:

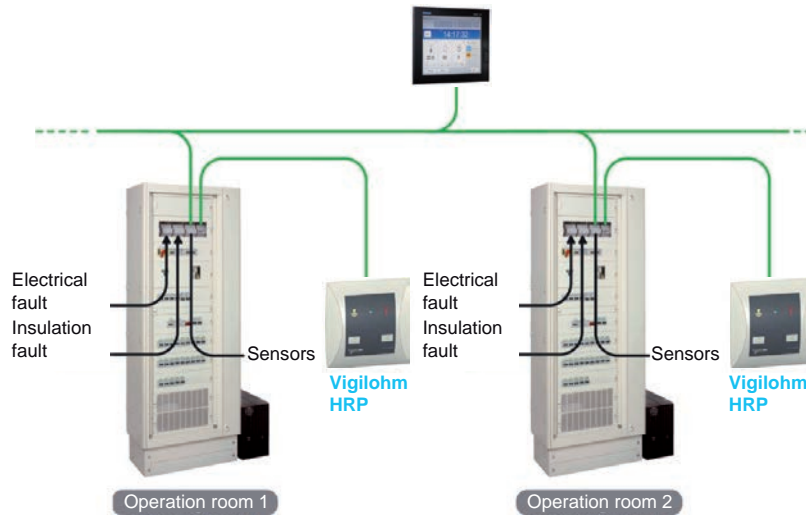

The HRP connection principle is illustrated in the following figure:

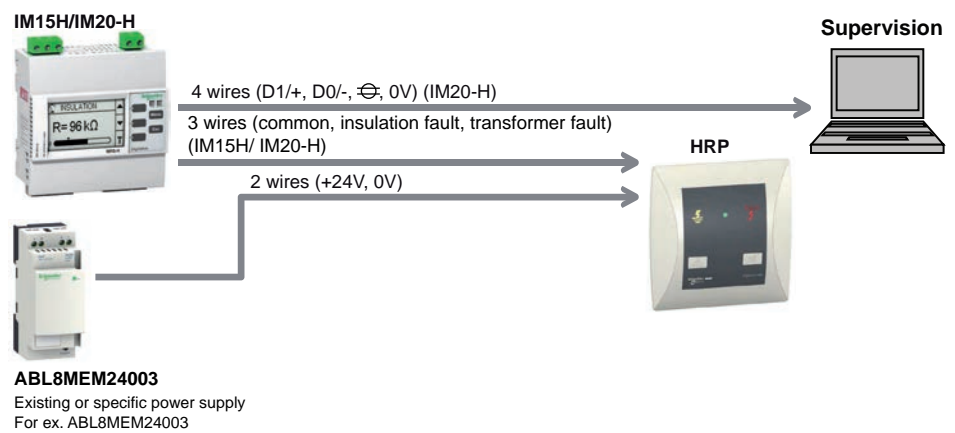



# Functions

## Monitoring power system insulation

The device monitors the ungrounded power system insulation in resistance in accordance with the following timing diagram which represents the default settings:

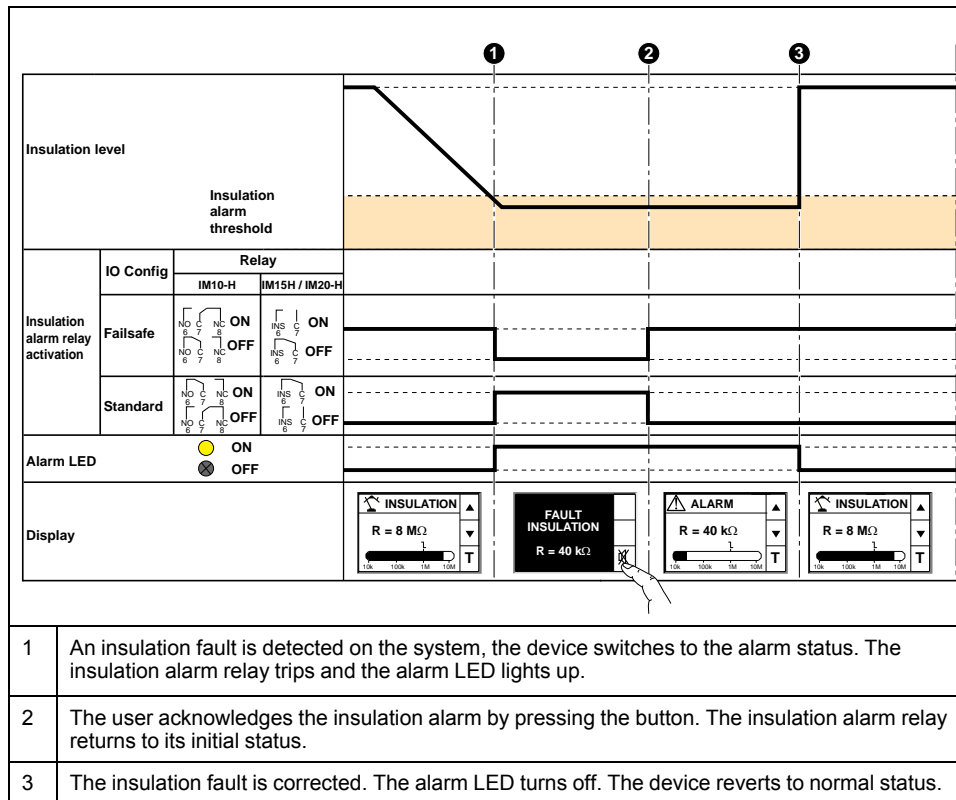

## Operating and Alarm LED information

The two bi-color indicator lights on the front panel indicate the device's current status.

ON LED	Alarm LED	Description
○	○	Device powered off
● flashes slowly	○	Device powered on, no insulation fault detected
● flashes slowly	●	Device powered on, insulation fault detected
●	○	Device powered on but malfunctioning

## Insulation alarm thresholds

You can set the threshold value as per the level of insulation of the application you monitor.

The allowed values for this parameter is from **50 kΩ** to **500 kΩ**. The default value is **50 kΩ**.

When the device is powered up, it retrieves the last insulation alarm threshold values recorded.

## Insulation alarm threshold hysteresis

A hysteresis is applied to limit the error in the insulation alarm due to fluctuations in the measurement when approaching threshold value.

A hysteresis principle is applied:

- When the insulation value measured decreases and falls below the setting threshold, the insulation alarm is triggered or the countdown is started if an insulation alarm time delay has been set.
- When the insulation value measured increases and exceeds 1.2 times the set threshold (i.e. the setting threshold+20%), the insulation alarm is deactivated.

The following diagrams show the behaviors:

- Without hysteresis:

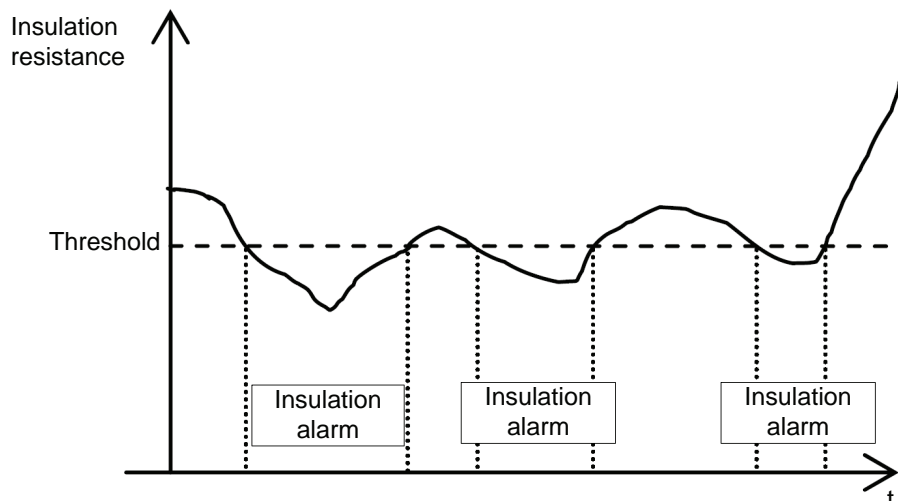

- With hysteresis:

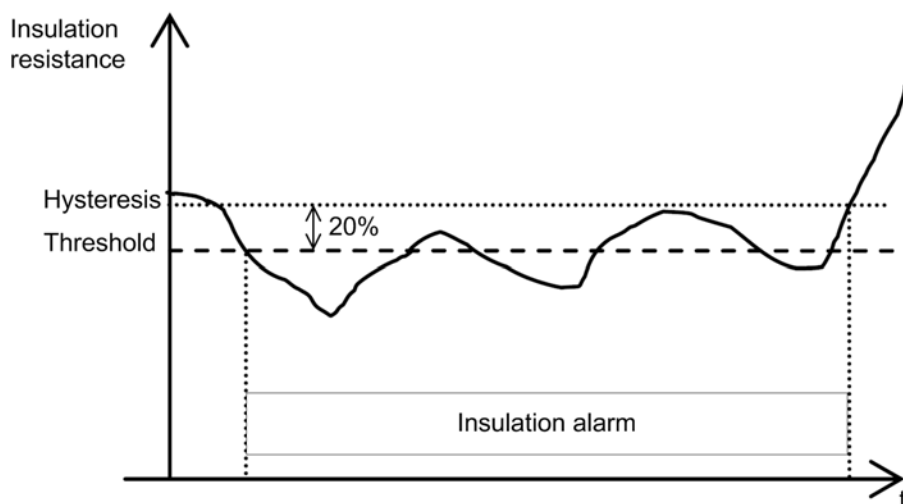

## Insulation alarm relay

You can set the insulation alarm relay mode depending on the status of insulation.

To access the setting, select **Menu > Settings > I/O config**.

- Parameter: **Relay**
- Allowed values: **FS / Std.**
- Default: **FS**

When the insulation alarm relay is configured in failsafe (**FS**) mode:

- The insulation alarm relay is activated, that is, energized, in the following case:
  - No insulation fault is detected.
- The insulation alarm relay is deactivated, that is, de-energized, in the following cases:
  - Insulation fault is detected.
  - The product is inoperative (detected by self-test).
  - The auxiliary power supply is lost.
  - When you trigger a self-test with relays, the relay toggles for 3 seconds.

When the insulation alarm relay is configured in standard (**Std.**) mode:

- The insulation alarm relay is activated, that is, energized, in the following cases:
  - Insulation fault is detected.
  - The product is inoperative (detected by self-test).
  - When you trigger a self-test with relays, the relay toggles for 3 seconds.
- The insulation alarm relay is deactivated, that is, de-energized, in the following cases:
  - No insulation fault is detected.
  - Insulation fault is detected and acknowledged (if **Menu > Settings > I/O Config. > Ack. AI. Relay** is set to **ON**).
  - The auxiliary power supply is lost.

## Insulation Alarm Relay Acknowledgement

You can set the insulation alarm relay acknowledgment as per the usage of loads connected to the relay.

When the relays are connected to loads (for example, horns or lamps), it is advised to turn off these external signaling devices before the insulation level rises back to a level above the setup thresholds. This can be done by pressing the acknowledge button while in insulation alarm state.

In certain system configurations, it is required to prevent this type acknowledgement and only retrigger the relays when the insulation level rises above the setup thresholds. This is done by changing the corresponding parameter.

The allowed values for this parameter are **ON** and **OFF**. The default value is **ON**.

### Acknowledge Alarm Relay ON

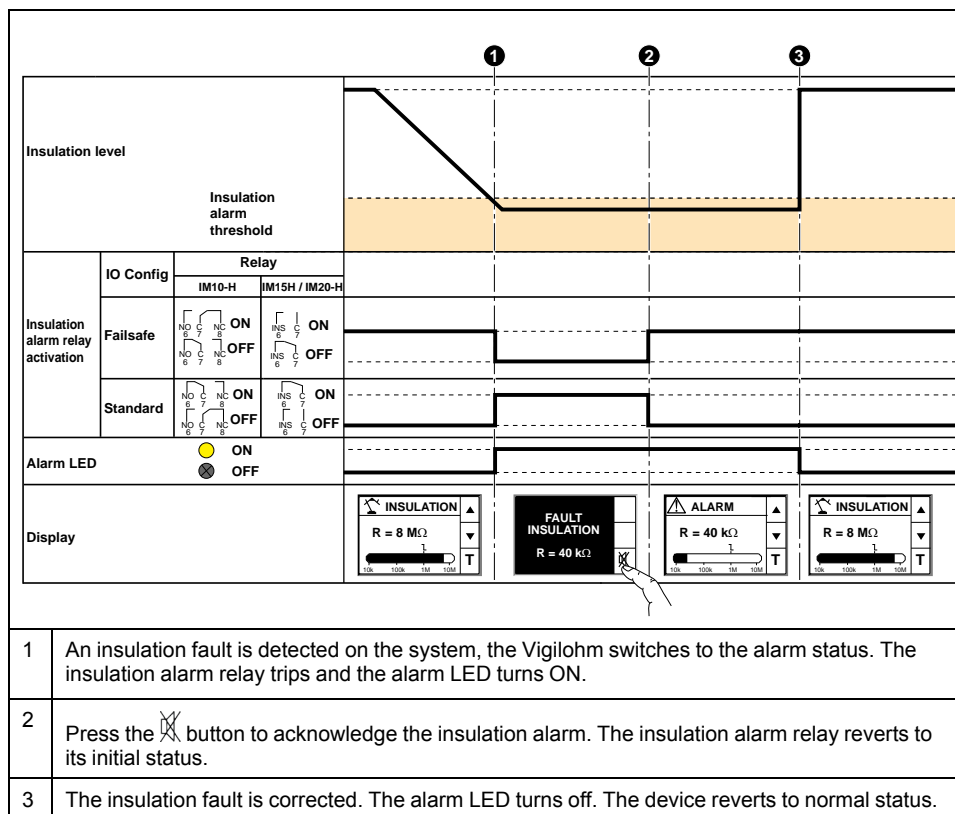

### Acknowledge Alarm Relay OFF

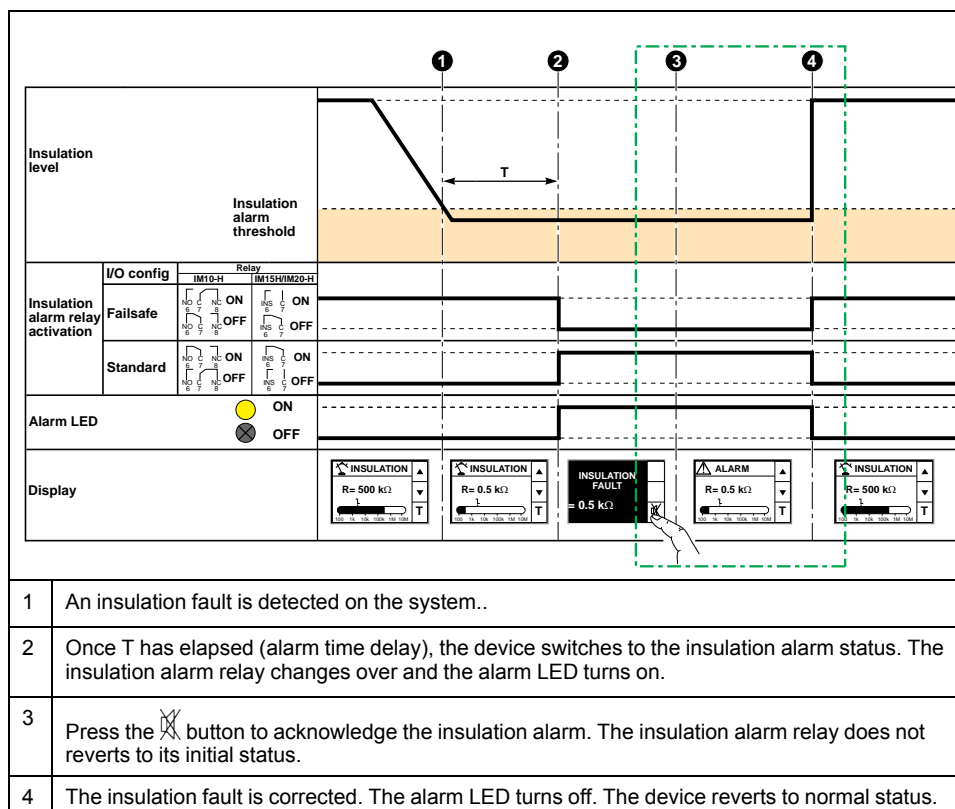

# Transformer Monitoring

## Introduction

The ungrounded system ensures safety through continuity of service. First insulation fault does not impact continuity of service. However, a system outage might occur during a transformer overload or short circuit. In such cases, the impact of short circuit can be limited by isolating the fault. The overloads and increases in temperature must be monitored in related to ungrounded system transformers.

The transformer monitoring function is integrated with IM15H or IM20-H. The IM10-H requires additional equipment to perform this function.

An overload or overheating might generate a transformer fault:

- On the IM15H or IM20-H, then the transformer faults take priority over an insulation fault on the display and the transformer alarm relay is activated.
- On the HRP, then the electrical fault red LED turns ON in the event of a transformer fault.
- On the Local Remote Display, the **Transformer Overload** or **Transformer Overheat** message is displayed.

## Monitoring of the transformer load

The transformer load consumption is measured continuously by an external current transformer and is displayed as a load percentage.

This consumed current is compared with an alarm threshold and, in case of overconsumption, the transformer alarm is generated on the HMI of the IM15H or IM20-H, on the HRP, **Transformer Overload** message is displayed on the Local Remote Display, sent via the Modbus communication (IM20-H) and the transformer alarm relay is activated.

The following parameters must be configured on the HMI of the IM15H or IM20-H or via Modbus communication (IM20-H):

Parameter	Allowed values	Default value
Primary CT	40...9999 A	50 A
Secondary CT	<ul style="list-style-type: none"> <li>• 1 A</li> <li>• 5 A</li> </ul>	5 A
Transformer nominal current	12...9999 A	36 A
Transformer overload threshold	1...100% (% of the nominal current)	80 %

## Monitoring of the transformer temperature

The transformer temperature is monitored by built-in temperature sensors.

These bimetal type sensors open or close when the temperature exceeds their setpoint threshold. If the transformer is equipped with several sensors having several thresholds, the "alarm temperature" sensor must be used.

<b>NOTICE</b>
<b>EQUIPMENT DAMAGE</b>
Configure the device according to the type of sensor.
<b>Failure to follow these instructions can result in equipment damage.</b>

Since the temperature sensors are installed on each column of the transformer, their wiring depends on the sensor type:

- Wire the NO bimetal temperature sensors (which close when the temperature exceeds the threshold) in parallel
  - Wiring of a single-phase transformer with two columns:

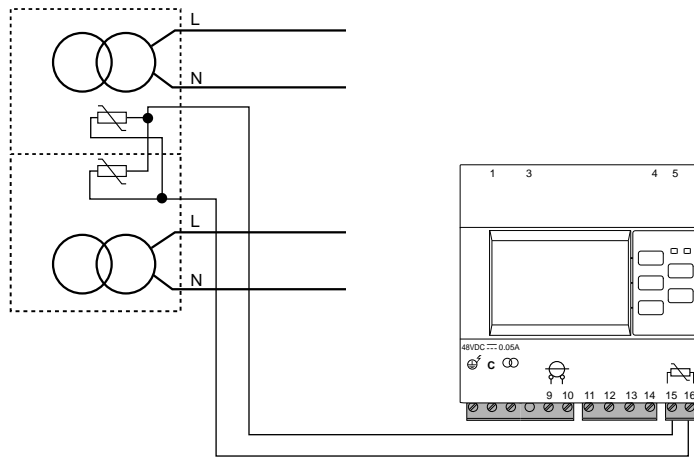

If the transformer has three columns, wire the third temperature sensor in parallel with the other two sensors.

- Configure the device by selecting **Menu > Settings > I/O config > Temp sensor > NO**
- NOTE:** The default sensor configuration of the device is NO (normally open).
- Wire the NC bimetal temperature sensors (which open when the temperature exceeds the threshold) in series

- Wiring of a single-phase transformer with two columns:

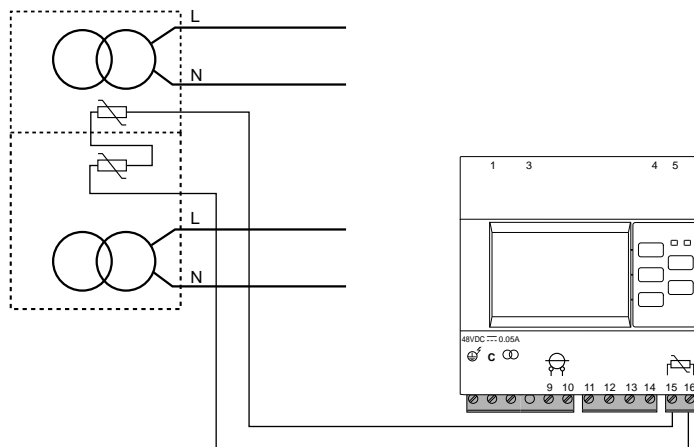

If the transformer has three columns, wire the third temperature sensor in series with the other two sensors.

- Configure the device by selecting **Menu > Settings > I/O config > Temp sensor > NC**

Pt••• type temperature sensors are not compatible with the device.

When overheating trips the bimetal sensor, a transformer alarm is generated on the HMI of the device, on the HRP, **Transformer Overheat** message is displayed on the Local Remote Display, sent via the Modbus communication and the transformer alarm relay is activated.

## Self-test

### Auto test overview

The device performs a series of self-tests on start-up, and then at regular intervals during operation, to help detect any potential faults in its internal and external circuits.

The device's auto test function tests:

- The product: indicator lights, internal electronics.
- The measuring chain and the insulation alarm relay.

The self-test is triggered:

- Manually at any time by pressing the **T** contextual menu button on one of the system insulation monitoring screens.
- Automatically:

Whenever the device starts up (power-up or reset)

Every 5 hours (except when the device has detected an insulation fault, regardless of whether the alarm is active, has been acknowledged, or is transient).

## Auto test sequence

During auto test, the device's indicator lights illuminate and information is shown on the display.

The following LEDs turn ON in sequence and turn OFF after the predefined time:

- **Alarm** white
- **ON** red
- **Alarm** yellow
- **ON** green

The relay toggles.

- If the auto test is successful, the following screen appears for 3 seconds and a status screen is displayed:



- If the auto test fails, the **Alarm** LED turns ON and a message is displayed to indicate that the product is malfunctioning. Disconnect the auxiliary power supply of device and reconnect. If the fault persists, contact technical support.

# Human Machine Interface

## Vigilohm IM10-H menu

Using the meter's display, you can navigate through the different menus to perform basic setup on your meter.

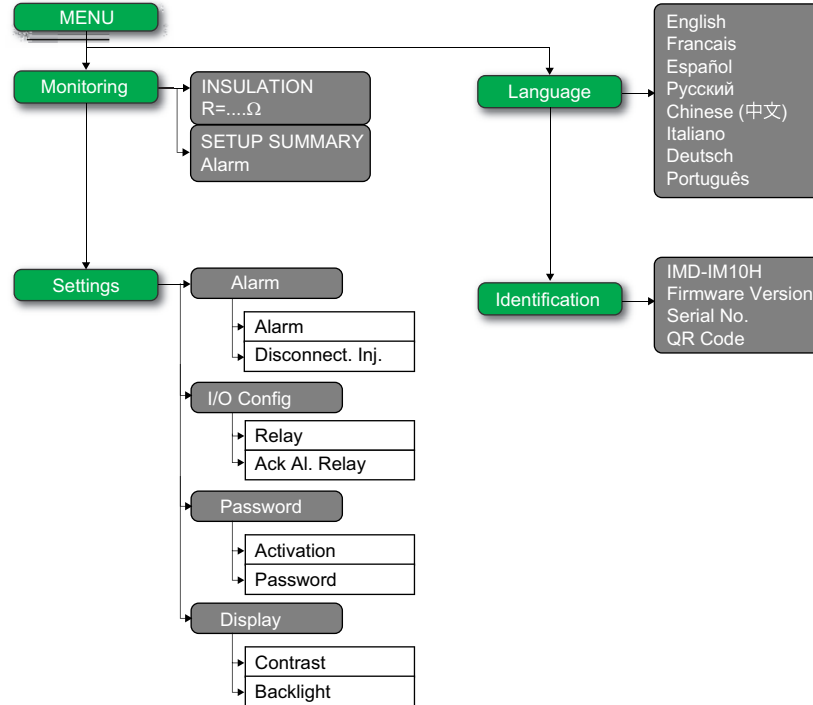

## Vigilohm IM15H / IM20-H menu

Using the meter's display, you can navigate through the different menus to perform basic setup on your meter.



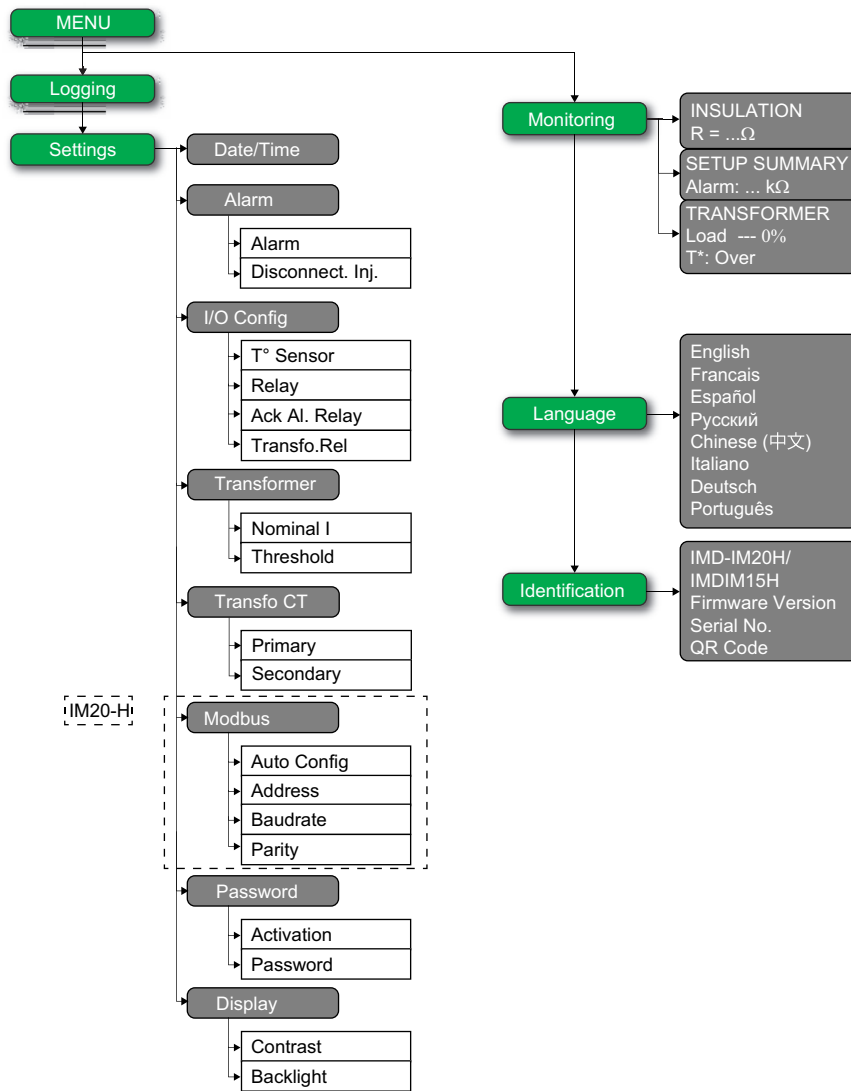

## Display interface

Use the device display to perform various tasks such as configuring the device, displaying status screens, acknowledging alarms, or viewing events.

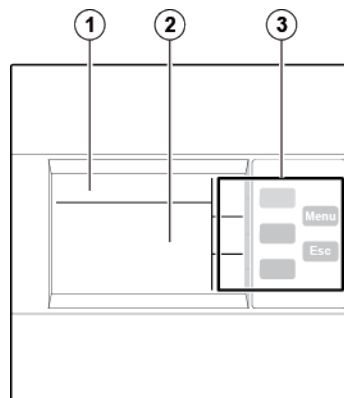

1	Screen identification area containing a menu icon, and the name of the menu or the parameter
2	Information area displaying information specific to the screen (measurement, insulation alarm, settings)
3	Navigation buttons

## Navigation buttons and icons

Use the display buttons to navigate through menus and perform actions.

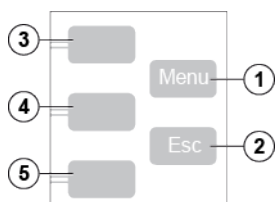

Legend	Button	Icon	Description
1	<b>Menu</b>	–	Display the level 1 menu ( <b>Menu</b> ).
2	<b>Esc</b>	–	Go back to the previous level.
3	Contextual menu button 3		Scroll up the display or move to the previous item in a list.
			Access the date and time setting. If the clock icon flashes, it means that the Date/Time parameter needs to be set.
			Increase a numerical value.
4	Contextual menu button 2		Scroll down the display or move to the next item in a list.
			Move one digit to the left within a numerical value. If the digit on the far left is already selected, pressing the button loops you back to the digit on the right.
			Validate the selected item.
5	Contextual menu button 1		Run the auto-test manually.
			Go to a menu or submenu, or edit a parameter.
			Acknowledge the insulation alarm.

## Information icons

Icons in the information area of the LCD display provide information such as what menu is selected and the insulation alarm status.

Icon	Description
	Main menu
	<ul style="list-style-type: none"> <li>System resistance (in the absence of an insulation fault)</li> <li>Measurement parameters menu</li> </ul>
	Fault log menu (IM20-H)
	Setting parameters menu and submenu
	Display language selection menu
	Product identification
	Indication of an insulation or transformer fault alarm

## Status screens

The default screen shows the insulation resistance value of the system. It is automatically replaced by a screen that notifies an insulation fault or a transformer fault (where applicable).

### Insulation resistance measurement (R)

The device displays the insulation resistance measurement for the system by default.

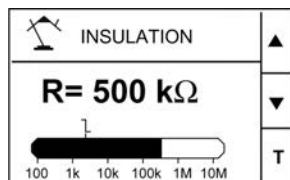

### Insulation alarm detected: insulation fault

The device displays the insulation fault screen when the insulation value falls below the insulation alarm threshold.

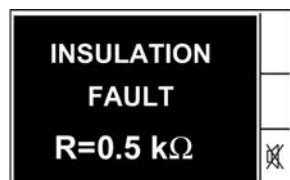

The screen flashes whenever an insulation or transformer alarm is detected.

Acknowledge the insulation alarm by pressing the  button.

### Insulation alarm acknowledged

This screen is displayed when you have acknowledged the insulation or transformer alarm.

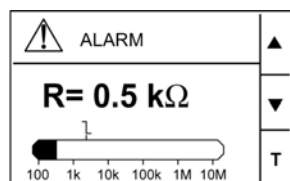

### Transformer alarm

This screen is displayed when transformer is overloaded or overheated.



Press the **OK** button to exit the screen. The alarm screen of the transformer concerned by the fault is then displayed.

- Example for transformer overload:

 TRANSFORMER		▲
Load:	114 %	▼
T:	OK	T

- Example for transformer overheat:

 TRANSFORMER		▲
Load:	63 %	▼
T:	Over	T

## Parameter modification using the display

To modify any of the values, you must be thoroughly familiar with the interface menu structure and general navigation principles.

For more information about how the menus are structured, see *Vigilohm IM15H / IM20-H menu, page 32*.

To modify the value of a parameter, follow either of these two methods:

- Select an item (value plus unit) in a list.
- Modify a numerical value, digit by digit.

For the following parameters, the numerical value can be modified:

- Date
- Time
- Password
- Modbus address ( IM20-H)

### Selecting a value in a list

To select a value in a list, use the up and down menu buttons to scroll through the parameter values until you reach the desired value, then press **OK** to confirm the new parameter value.

### Modifying a numerical value

The numerical value of a parameter is made up of digits and the one on the far right is selected by default. To modify a numerical value, use the menu buttons as follows:

- **+** to modify the selected digit.
- **←** to select the digit to the left of the one that is currently selected, or to loop back to the digit on the right.
- **OK** to confirm the new parameter value.

### Saving a parameter

After you have confirmed the modified parameter, one of following two actions occur:

- If the parameter has been saved correctly, the screen displays **Saved** and then returns to the previous display.
- If the parameter has not been saved correctly, the screen displays **Error** and the editing screen remains active. A value is deemed to be out of range when it is classed as forbidden or when there are several interdependent parameters.

## Canceling an entry

To cancel the current parameter entry, press the **Esc** button. The previous screen is displayed.

## Clock

Applicable for IM20-H / IM15H.

The date/time must be set:

- On first power up.
- Whenever factory reset is performed.
- Whenever the power supply is interrupted.
- When switching between summer and winter time and vice versa.

If the auxiliary power supply is interrupted, the device retains the date and time setting from immediately before the interruption. The device uses the date and time parameter to time-tag the system insulation faults recorded. The date is displayed in the format: dd/mm/yyyy. The time is displayed using the 24-hour clock in the format: hh/mm

When the device is powered up, the clock icon flashes on the system monitoring screens to indicate that the clock needs to be set. To set the date and time, see *Parameter modification using the display, page 36*.

## Insulation fault log

Applicable for and IM20-H / IM15H.

The device records the details of the 30 most recent insulation fault events. The fault events are triggered by one of following statuses:

- insulation fault
- transformer overload
- transformer overheating

Event 1 is the event that was recorded most recently and event 30 is the oldest recorded event.

The oldest event is deleted when a new event occurs (the table is not reset).

By referring to this information, the performance of the distribution system can be improved and maintenance work is facilitated.

## Insulation fault log display screen

You can the view the details of an insulation fault event by navigating to **Menu > Logging**.

1	Insulation fault value or load percentage recorded
2	Type of fault recorded: <ul style="list-style-type: none"> <li>• insulation fault</li> <li>• transformer overload</li> <li>• transformer overheating</li> </ul> <p><b>NOTE:</b> These faults are recorded as primary record.</p>

3	Date and time when the fault appeared <b>NOTE:</b> This information is stored as primary record.
4	Date and time when the fault disappeared due to any one of the following event: <ul style="list-style-type: none"><li>• <del>X</del> Insulation fault acknowledgement/Insulation or transformer fault acknowledgement</li><li>• <math>\int</math> Transient fault</li><li>• <math>\perp</math> Disappearance of the transformer overload</li></ul> <b>NOTE:</b> This information is stored as secondary record.
5	Number of the event displayed
6	Total number of events recorded

Use the up and down arrows to scroll through the events.

# Communication

Communication is applicable for IM20-H

## Communication Parameters

Before initiating any communication with the device, you must configure the Modbus communication port. You can configure communication parameters by selecting (**Menu > Settings > Modbus**).

The communication parameters and its allowed and default values are as follows:

Parameter	Default value	Allowed values
Address	1	1...247
Baud rate	19200	<ul style="list-style-type: none"> <li>• 4800</li> <li>• 9600</li> <li>• 19200</li> <li>• 38400</li> </ul>
Parity	Even	<ul style="list-style-type: none"> <li>• None</li> <li>• Even</li> <li>• Odd</li> </ul>

To modify the parameter value, see *Parameter modification using the display*, page 36.

## Modbus functions

The device supports Modbus function codes.

Function Code		Function Name
Decimal	Hexadecimal	
3	0x03	Read Holding Registers <sup>1</sup>
4	0x04	Read Input Registers <sup>1</sup>
6	0x06	Write Single Register
8	0x08	Diagnostic Modbus
16	0x10	Write Multiple Registers
43 / 14	0x2B / 0E	Read Device Identification
43 / 15	0x2B / 0F	Get Date/Time
43 / 16	0x2B / 10	Set Date/Time

### Read Device Identification request

Number	Type	Value
0	VendorName	Schneider Electric
1	ProductCode	IM20-H
2	MajorMinorRevision	vX.Y.Z
3	VendorURL	www.schneider-electric.com
4	ProductName	Insulation Monitoring Device
5	ModelName	IMD-IM20-H

1. The Read Holding and Read Input registers are identical.

The device answers any type of requests (basic, regular, extended).

## Modbus register table format

Register tables have the following columns.

Column heading	Description
Address	The address of the Modbus, in decimal (dec) and hexadecimal (hex) formats.
Register	The register of the Modbus, in decimal (dec) and hexadecimal (hex) formats.
R/W	Read only (R) or read/write (R/W) register.
Unit	The unit in which the information is expressed.
Type	The coding data type.
Range	Permitted values for this variable, usually a subset of what the format allows.
Description	Provides information about the register and the values applied.

## Modbus registers table

The following table lists the Modbus registers that apply to your device.

### System status registers

Address		Register		R/W	Unit	Type	Range	Description
dec	hex	dec	hex					
100	64	101	65	R	–	Uint16	–	Product identifier <ul style="list-style-type: none"> <li>17001 - IM10–H</li> <li>17003 - IM20–H</li> <li>17009 - IM15H</li> </ul>
114..115	72...73	115...116	73...74	R	–	Uint32	–	Product state <ul style="list-style-type: none"> <li>Bit1 - Reserved</li> <li>Bit2 - Self test</li> <li>Bit3 - Reserved</li> <li>Bit4 - Reserved</li> <li>Bit5 - Monitoring</li> <li>Bit6 - Reserved</li> <li>Bit7 - Product error</li> <li>Bit8 - System error</li> <li>Bit9 - Injection disabled</li> <li>Bit10 - Reserved</li> </ul>
116	74	117	75	R	–	Uint16	–	Product error codes <ul style="list-style-type: none"> <li>0xFFFF - No error</li> <li>0x0000 - Unknown error</li> <li>0x0DEF - Undefined model</li> <li>0xAF00 - Auto-test failure</li> <li>0xBE00 - Metering</li> <li>0x5EFA - Sensor call problem</li> <li>0xD1A1 - Glued IO</li> <li>0xD1A2 - RAM</li> <li>0xD1A3 - EEPROM</li> <li>0xD1A4 - Relay</li> <li>0xD1A5 - Status input</li> <li>0xD1A6 - Flash</li> </ul>



## System status registers (Continued)

Address		Register		R/ W	Unit	Type	Range	Description
dec	hex	dec	hex					
								<ul style="list-style-type: none"> <li>• 0xD1A7 - SIL</li> <li>• 0xE000 - NMI interrupt</li> <li>• 0xE001 - Hard fault exception</li> <li>• 0xE002 - Memory fault exception</li> <li>• 0xE003 - Bus fault exception</li> <li>• 0xE004 - Usage fault exception</li> <li>• 0xE005 - Unexpected interrupt</li> </ul>
120...1-39	78...8B	121...140	79...8C	R	–	UTF8	–	Product family
140...1-59	8C...9F	141...160	8D...A0	R/ W	–	UTF8	–	Product name
160...1-79	A0...B3	161...180	A1...B4	R	–	UTF8	–	Product model <ul style="list-style-type: none"> <li>• IMD-IM10H</li> <li>• IMD-IM20H</li> <li>• IMDIM15H</li> </ul>
180...1-99	B4...C7	181...200	B5...C8	R	–	UF8	–	Manufacturer: Schneider Electric
208...2-19	D0...DB	209...220	D1...DC	R	–	UF8	–	ASCII serial number
220	DC	221	DD	R	–	Uint16	–	Manufacturing unit identifier
300...3-06	12C...-132	301...307	12D...133	R	–	Uint16	–	Date and time in 7 register format The following parameters correspond to each register: <ul style="list-style-type: none"> <li>• 300 - Year</li> <li>• 301 - Month</li> <li>• 302 - Day</li> <li>• 303 - Hour</li> <li>• 304 - Minute</li> <li>• 305 - Second</li> <li>• 306 - Millisecond</li> </ul>
307...3-10	133...1-36	308...311	134...137	R/ W	–	Uint16	–	Date and time in TI081 Format
320...3-24	140...1-49	321...325	141...145	R	–	Uint16	–	Present firmware version <ul style="list-style-type: none"> <li>• X represents the primary revision number, which is encoded in register 321</li> <li>• Y represents the secondary revision number, which is encoded in register 322</li> <li>• Z represents the quality revision number, which is encoded in register 323</li> </ul>

**Modbus**

Address		Register		R/ W	Unit	Type	Range	Description
dec	hex	dec	hex					
750	2EE	751	2EF	R/ W	–	Uint16	1...247	Device address Default value: 1
751	2EF	752	2F0	R/ W	–	Uint16	<ul style="list-style-type: none"> <li>• 0 = 4800</li> <li>• 1 = 9600</li> <li>• 2 = 19200</li> <li>• 3 = 38400</li> </ul>	Baud rate Default value: 2 (19200)
752	2F0	753	2F1	R/ W	–	Uint16	<ul style="list-style-type: none"> <li>• 0 = Even</li> <li>• 1 = Odd</li> <li>• 2 = None</li> </ul>	Parity Default value: 0 (Even)

**Insulation monitoring registers**

Address		Register		R/ W	Unit	Type	Range	Description
dec	hex	dec	hex					
1020...- 1021	3F- C...3FD	1021...10- 22	3FD...3FE	R	Ohm	Float32	–	Resistance  The value NaN (Not a Number) 0xFFC00000 is returned during the self-test.
1032...- 1033	408...4- 09	1033...10- 34	409...40A	R	%	Float32	–	Transformer load current  The value NaN (Not a Number) 0xFFC00000 is returned during the self-test.
1034	40A	1035	40B	R	–	Uint16	<ul style="list-style-type: none"> <li>• 0 = Correct temperature</li> <li>• 1 = Temperature too high</li> </ul>	Transformer overheat

## Insulation alarm

Address		Register		R/W	Unit	Type	Range	Description
dec	hex	dec	hex					
1100	44C	1101	44D	R	–	Uint16	<ul style="list-style-type: none"> <li>• 0 = No alarm</li> <li>• 1 = Insulation alarm active</li> <li>• 8 = Insulation alarm acknowledged</li> </ul>	Insulation alarm
1101	44D	1102	44E	R	–	Uint16	<ul style="list-style-type: none"> <li>• 0 = No alarm</li> <li>• 1 = Overload alarm</li> <li>• 2 = Overheating alarm</li> <li>• 3= Overload and overheating alarms active</li> </ul>	Transformer alarm
1110...1-111	456...45-7	1111...1-112	457...458	R	–	Uint32	–	Product status <ul style="list-style-type: none"> <li>• 0 - No alarm</li> <li>• Bit 1 - Active alarm</li> <li>• Bit 2 - Reserved</li> <li>• Bit 3 - Reserved</li> <li>• Bit 4 - Alarm acknowledged</li> <li>• Bit 5 - Reserved</li> <li>• Bit 6 - Reserved</li> <li>• Bit 7 - Reserved</li> <li>• Bit 8 - Reserved</li> <li>• Bit 9 - First measurement</li> <li>• Bit 10 - Reserved</li> <li>• Bit 11 - Reserved</li> <li>• Bit 12 - Reserved</li> <li>• Bit 13 - Self test</li> <li>• Bit 14 - Reserved</li> <li>• Bit 15 - Reserved</li> <li>• Bit 16 - Reserved</li> <li>• Bit 17 - Disconnected injection</li> <li>• Bit 18 - Over limit capacitance</li> <li>• Bit 19 - Reserved</li> <li>• Bit 20 - Transformer over load</li> <li>• Bit 21 - Transformer over heat</li> <li>• Bit 22 - Reserved</li> <li>• Bit 23 - Transformer over load acknowledged</li> <li>• Bit 24 - Transformer over heat acknowledged</li> <li>• Bit 25 - Device error</li> <li>• Bit 26 - Reserved</li> <li>• Bit 27 - Reserved</li> <li>• Bit 28 - Reserved</li> <li>• Bit 29 - Reserved</li> <li>• Bit 30 - Reserved</li> <li>• Bit 31 - Reserved</li> <li>• Bit 32 - Power Down</li> </ul>

## Diagnostics

Address		Register		R/W	Unit	Type	Range	Description
dec	hex	dec	hex					
2000	7D0	2001	7D1	W	–	Uint16	0xA456 = run self-test	Run the self-test of the product without testing the relay (same as the self-test cycle).
2005...-2006	7D5...7-D6	2006...2-007	7D6...7D7	R	–	Uint32	–	Total number of power cycles since first power-up of the product

## Settings

Address		Register		R/W	Unit	Type	Range	Description
dec	hex	dec	hex					
3000	BB8	3001	BB9	R/W	—	Uint16	<ul style="list-style-type: none"> <li>0 = Normally open</li> <li>1 = Normally closed</li> </ul>	Temperature sensor Default value: 0 (Normally open)
3001	BB9	3002	BBA	R/W	–	Uint16	<ul style="list-style-type: none"> <li>1 = Standard</li> <li>2 = Failsafe</li> </ul>	Insulation alarm relay logic command Default value: 2 (Failsafe)
3002...-3003	BBA...BBB	3003...3-004	BBB...BBC	R/W	Ohm	Uint32	50...500 kΩ	Insulation alarm threshold Default value: 50 kΩ
3010	BC2	3011	BC3	R/W	A	Uint16	<ul style="list-style-type: none"> <li>1 A</li> <li>5 A</li> </ul>	Transformer CT, secondary Default value: 5 A
3011	BC3	3012	BC4	R/W	A	Uint16	30...9999 A	Transformer CT, primary Default value: 50 A
3012	BC4	3013	BC5	R/W	%	Uint16	1...100%	Transformer overload threshold Default Value : 80%
3013	BC5	3014	BC6	R/W	A	Uint16	12...9999 A	Transformer nominal current Default value : 36 A
3014	BC6	3015	BC7	R/W	–	Uint16	0000...9999	Password Default value: 0000
3015	BC7	3016	BC8	R/W	–	Uint16	<ul style="list-style-type: none"> <li>0 = OFF</li> <li>1 = ON</li> </ul>	Password protection Default value: 0 (password protection deactivated)
3016	BC8	3017	BC9	R/W	–	Uint16	<ul style="list-style-type: none"> <li>0 = English</li> <li>1 = French</li> <li>2 = Spanish</li> <li>3 = Russian</li> <li>4 = Chinese</li> <li>5 = Italian</li> <li>6 = German</li> <li>7 = Portuguese</li> </ul>	Interface language Default value: 0 (English)
3017	BC9	3018	BCA	R/W	%	Uint16	10...100%	Screen contrast Default value: 50%
3018	BCA	3019	BCB	R/W	%	Uint16	10...100%	Screen brightness. Default value: 100%
3020	BCC	3021	BCD	R/W	–	Uint16	<ul style="list-style-type: none"> <li>1 = Standard</li> <li>2 = Failsafe</li> </ul>	Logical command of the transformer alarm relay Default value: 2 (Failsafe)

## Logging

Address		Register		R/W	Unit	Type	Range	Description
dec	hex	dec	hex					
19996... .19997	4E1- C...4E1- D	19997...- 19998	4E1D...4- E1E	R	–	Unit32	–	Roll over counter
19998...- .19999	4E1- E...4E1F	19999...- 20000	4E1F...4- E20	R	–	Uint16	1...240	Number of event records
20001	4E21	20002	4E22	R	–	Uint16	–	Most recent record number
20002...- .20013	4E22...- 4E2D	20003...- 20014	4E23...4- E2E	R	–	Record	–	Record 1
20014...- .20025	4E2- E...4E39	20015...- 20026	4E2F...4- E3A	R	–	Record	–	Record 2
...								
20710...- .20721	50E6...- 50F1	20711...- 20722	50E7...50- F2	R	–	Record	–	Record 60

## Alarm event records

Each event is stored using two records:

- A "primary" record, which is created when the insulation alarm or transformer alarm occurs. This contains the insulation value, transformer load, or status of the transformer temperature sensor.
- A "secondary" record, which is created when the insulation alarm or transformer alarm disappears. This contains the type of event (acknowledged insulation alarm, disappearance of overload or overheating event).

The 2 records are not logged consecutively. For example, transformer alarm can occur during an insulation fault.

### Description of an Event Record in the Log

Register	Unit	Type	Range	Description
Word 1	–	Uint16	1...65535	Event record number
Word 2 Word 3 Word 4 Word 5	–	Uint64	–	Time tagging of event (using the same code as for the product date/ time)
Word 6 Word 7	–	Uint32	<ul style="list-style-type: none"> <li>• 0...1</li> <li>• 0x40, 0x10</li> <li>• 1020...1021, 1032...1033, 1034, 1100, 1101</li> </ul>	Record identifier: <ul style="list-style-type: none"> <li>• Word 6, most significant byte: information for primary/ secondary record. This field takes the value 1 for the primary record and value 0 for the secondary record.</li> <li>• Word 6, least significant byte: type of data stored in the Value field.</li> <li>• Word 7: address of the Modbus register that is the source of the data in the Value field.</li> </ul>

**Description of an Event Record in the Log (Continued)**

Register	Unit	Type	Range	Description
Word 8 Word 9 Word 10 Word 11	–	Uint64	–	Depending on the type of record (primary or secondary): <ul style="list-style-type: none"> <li>• Primary record (when the event occurs):                             <ul style="list-style-type: none"> <li>◦ Insulation resistance value (in Ohm) when the event occurred (coded in Float32 in the last 2 registers).</li> <li>◦ Transformer load (as a % of the nominal load encoded in Uint32 in the last 2 registers)</li> <li>◦ Status of bimetal strip (encoded in Uint16 in the last register)</li> </ul> </li> <li>• Secondary record (when the event disappears or is acknowledged) — Type of insulation or transformer alarm (encoded in Uint16 on the last register)</li> </ul>
Word 12	–	Uint16	1...65534	Primary/secondary record identifier for the event: <ul style="list-style-type: none"> <li>• In the case of a primary record for an event, this identifier is an odd integer; numbering starts at 1 and the number is incremented by 2 for each new event.</li> <li>• In the case of a secondary record for an event, this identifier is equal to the primary record identifier plus 1.</li> </ul>

**Example of an event**

The next 2 records relate to an example insulation alarm that occurred on October 1, 2010 at 12:00 pm and was acknowledged at 12:29 pm.

**Record number: 1**

Address		Register		Unit	Type	Value	Description
dec	hex	dec	hex				
20002	4E22	20003	4E23	–	Uint16	1	Record number
20003	4E23	20004	4E24	–	Uint64	<ul style="list-style-type: none"> <li>• 10</li> <li>• 0</li> <li>• 10</li> <li>• 1</li> <li>• 12</li> <li>• 0</li> <li>• 0</li> </ul>	Date when insulation alarm occurred (October 1, 2010, 12:00 pm)
20007	4E27	20008	4E28	–	Uint32	<ul style="list-style-type: none"> <li>• 1</li> <li>• 0x40</li> <li>• 1000</li> </ul>	Record identifier: <ul style="list-style-type: none"> <li>• Primary record plus secondary record</li> <li>• Float32 value (insulation resistance)</li> <li>• Value of register 1000 (register for insulation resistance monitoring)</li> </ul>
20009	4E29	20010	4E2A	Ohm	Uint64	10000	Insulation resistance value at the time of the insulation alarm
20013	4E2D	20014	4E2E	–	Uint16	1	Secondary record identifier for the event

**Record number: 2**

Address		Register		Unit	Type	Value	Description
dec	hex	dec	hex				
20014	4E2E	20015	4E2F	–	Uint16	2	Record number
20015	4E2F	20016	4E30	–	Uint64	<ul style="list-style-type: none"> <li>• 10</li> <li>• 0</li> <li>• 10</li> <li>• 1</li> </ul>	Date when insulation alarm disappeared (October 1, 2010, 12:29 pm)

**Record number: 2 (Continued)**

Address		Register		Unit	Type	Value	Description
dec	hex	dec	hex				
						<ul style="list-style-type: none"> <li>• 12</li> <li>• 29</li> <li>• 0</li> </ul>	
20019	4E33	20020	4E34	–	Uint32	<ul style="list-style-type: none"> <li>• 1</li> <li>• 0x10</li> <li>• 1000</li> </ul>	Record identifier: <ul style="list-style-type: none"> <li>• Secondary record</li> <li>• Uint16 value (alarm acknowledged)</li> <li>• 1100 register value (insulation alarm status register).</li> </ul>
20021	4E35	20022	4E36	–	Uint64	8	Value of insulation alarm register at the time of insulation alarm acknowledgement
20025	4E39	20026	4E3A	–	Uint16	2	Secondary record identifier for the event

# Maintenance

## Safety Precautions

The following safety precautions must be thoroughly implemented before attempting to commission the system, repair electrical equipment or carry out maintenance.

Carefully read and follow the safety precautions described below.

### ⚠ DANGER

#### HAZARD OF ELECTRIC SHOCK, EXPLOSION, OR ARC FLASH

- Apply appropriate personal protective equipment (PPE) and follow safe electrical work practices. See NFPA 70E in the USA, CSA Z462 or applicable local standards.
- Turn off all power supplying this device and the equipment in which it is installed before working on the device or equipment.
- Always use a properly rated voltage sensing device to confirm that all power is off.

**Failure to follow these instructions will result in death or serious injury.**

### NOTICE

#### EQUIPMENT DAMAGE

- Do not open this unit.
- Do not attempt to repair any components of this product or any of its accessory products.

**Failure to follow these instructions can result in equipment damage.**

## Disconnected Injection Detection

By default, your Vigilohm device displays a message if it does not detect an injection signal.

If the injection circuit of Vigilohm is interrupted, the display shows the message below and starts flashing:



By default, the disconnected injection detection parameter is activated (parameter **Disconnect. Inj.** set to **ON**) in Vigilohm.

When installing and commissioning the unit and the electrical panel, before you plug the equipment to the electrical power system, set parameter **Disconnect. Inj.** to **OFF** to prevent the message **Wiring Connection Lost** from being displayed.

Depending on the demands of the electrical network or the application, during the final commissioning, you may need to reactivate the disconnected injection detection parameter (by selecting **Settings > Alarm > Disconnect. Inj.** set to **ON**). In this way, your Vigilohm device monitors constantly during operation and reports any injection connection or wiring problem.



## ON light indicator

If the **ONProduct status** light indicator is red, there is an error in the power system or your device.

The error is one of the following cases:

- Interruption of the injection circuit
- Auto test not OK
- Device fault
- System error
- Over limit capacitance ( $C > 60 \mu\text{F}$  (or  $> 150 \mu\text{F}$  with a high voltage adapter))

## Troubleshooting

There are some checks you can perform to try to identify potential issues with the device's operation.

The following table describes potential problems, their possible causes, checks you can perform and possible solutions for each. After referring to this table, if you cannot resolve the problem, contact your local Schneider Electric sales representative for assistance.

Potential problem	Possible cause	Possible solution
The device displays nothing when switched on.	No power supply to the device.	Check that the auxiliary power supply is present.
	The auxiliary power supply is not compliant.	Check the auxiliary voltage: $U = 90\text{--}265 \text{ Vac}$
The device notified an insulation fault, but your system shows no signs of abnormal behavior.	The insulation alarm threshold is not appropriate.	Check the value of the insulation alarm threshold. Modify the insulation alarm threshold as appropriate.
You deliberately created an insulation fault, but the device failed to detect it.	The resistance value used to simulate the fault is greater than the value of the insulation alarm threshold.	Use a resistance value that is lower than the insulation alarm threshold or modify the insulation alarm threshold.
	The fault is not detected between neutral and ground.	Start again ensuring you are between neutral and ground.
The <b>ON</b> indicator light is red and the display shows <b>WIRING CONNECTION LOST</b> .	No electrical installation has been connected to the electrical panel when commissioning.	<ul style="list-style-type: none"> <li>• Check the connection on the injection terminal block (terminals 1 and 3) and restart the self-test.</li> <li>• Disable the function during commissioning.</li> </ul>
	The injection wire or the ground wire for the device is cut.	
	The device considers an electrical power system with low capacitance and high resistance to be a disconnected injection.	
The <b>ON</b> indicator light is red and the display indicates that an error occurred during the self-test.	The device's injection circuit is cut off.	Briefly disconnect the auxiliary power supply to the device.
Although the device is being supplied with power, the <b>ON</b> indicator light does not light up.	Faulty indicator light.	Restart the self-test and check that the <b>ON</b> indicator light lights up briefly.
The <b>Alarm</b> indicator light does not light up in the event of a fault.	Faulty indicator light.	Restart the self-test and check that the <b>Alarm</b> indicator light lights up briefly.

## Specifications

This section provides additional specifications for your device and accessories.

The information contained in this section is subject to change without notice. You can download updated documentation from [www.schneider-electric.com](http://www.schneider-electric.com) or contact your local Schneider Electric representative for the latest updates.

See your device's installation sheet for specifications related to installation, such as measured current and voltage ranges, inputs/outputs and control power information.

### System type to be monitored

AC or combined AC/DC ungrounded power systems	Phase-to-phase voltage with device connected to neutral	0...230 V AC (+15%)
	With device connected to phase	0...230 V DC (+15%)
	Frequency (AC system)	50/60 Hz

### Electrical characteristics

Range for insulation resistance readings		0.1 k $\Omega$ ...10 M $\Omega$
Fault notification	Number of thresholds	1(password protected)
	Thresholds	50...500 k $\Omega$
	Insulation alarm threshold hysteresis	20%
Response time		$\leq$ 1 s
Device operating test		Self-testing and manual testing
Internal impedance		110 k $\Omega$ (at 50 Hz)
IM10-H Output contact	Number	1 (NO/NC)
	Type of contact	Changeover
	Breaking capacity	250 V AC 6 A
IM15H / IM20-H Output contact	Number	2 (NO)
	Type of contact	Static
	Breaking capacity	12...48 V DC 50 mA
Transformer monitoring	Load current input	Nominal current: 1 A /5 A Maximum current: 6 A
	Temperature input (Bi metallic sensor)	Voltage supplied: 24 V DC Minimum load: 5 mA
Auxiliary power supply voltage	50/60 Hz	110...230 V AC $\pm$ 15%
	DC	125...250 V DC $\pm$ 15%
Burden		12 VA
Measurement voltage peak		25 V
Measurement current peak		0.2 mA
Dielectric withstand		4000 V AC / 5500 V DC

### Mechanical characteristics

Weight	0.25 kg
Mounting methods	Panel or DIN rail

**Mechanical characteristics (Continued)**

IP degree of protection	IP52 (front)
Mounting position	Vertical

**Environmental characteristics**

Operating temperature	-25...+55°C
Storage temperature	-40...+70°C
Climatic conditions <sup>2</sup>	IEC 60068
Location	For indoor use only
Altitude	≤ 3000 m (9843 ft)
Pollution degree	2

**Other**

Standards	Product	IEC 61557-8
	Safety	IEC 61010-1 <sup>3</sup>
	Installation	IEC 60364-7-710

2. The device is suitable for use in all climates:
  - Damp, equipment not operating (IEC 60068-2-30)
  - Damp heat, equipment operating (IEC 60068-2-56)
  - Salt mist (IEC 60068-2-52)
3. The rated operational voltage is 200 V L-N under the IEC 61010-1 standard.

Schneider Electric  
35 rue Joseph Monier  
92500 Rueil Malmaison  
France

+ 33 (0) 1 41 29 70 00

[www.schneider-electric.com](http://www.schneider-electric.com)

As standards, specifications, and design change from time to time,  
please ask for confirmation of the information given in this publication.

© 2018 – Schneider Electric. All rights reserved.

VIGED310023EN-04